



ENHANCING SAFETY MEASURES IN METRO RAIL BY USING PLC AND SCADA

Sindhu Bharathi B, Nivedha R , Swedha S

Department Of EEE

Vel Tech High Tech Dr. Rangarajan Dr.Sakunthala Eng College

Avadi, Chennai

sindhub692@gmail.com, nivedharg@gmail.com, Swedhafabien56@gmail.com

ABSTRACT

Metro Rail is the upcoming rapid transit system in Chennai. In Metro Rail system Automatic Train Protection and Automatic Train Operation is being employed. In this paper we are going to overcome certain disadvantages that are encountered in Metro Rail system. If a train enters a tunnel or cave there may be a greater possibility of electrical interruption. In such a case signal monitoring and controlling becomes difficult. Hence it leads to train accidents. In order to overcome this problem Programmable Logic Controllers are being employed for automatic signal controlling and continuous monitoring by using SCADA when a train stops inside a tunnel. In addition inter passage door is opened automatically for the safe exit of passengers from the tunnels. Ladder arrangement is provided at the top of the tunnels for the passengers to come out of the tunnels easily.

Keywords-PLC, Power Outage, RFID, Tunnel, SCADA

1. INTRODUCTION

A Programmable Logic Controller, PLC or Programmable Controller is a digital computer used for automation of electromechanical processes, such as control of machinery on factory assembly lines, amusement rides, or light fixtures. PLCs are used in many industries and machines. Unlike general-purpose computers, the PLC is designed for multiple inputs and output arrangements, extended temperature ranges, immunity to electrical noise, and resistance to vibration and impact. Programs to control machine operation are typically stored in battery-backed-up or non-volatile memory. A PLC is an example of a hard real-time system since output results must be produced in response to input conditions within a limited time, otherwise unintended operation will result. Train accidents occur due to various reasons. It may be due to the fault of driver, electrical interruption, signaling problems, human errors etc. In Chennai Metro Rail

System Automatic Train Protection, Automatic Train Operation and Automatic Fare Collection Methods [2] are employed. These methods can avoid head to head collision and accidents caused due to the mistake of driver. Metro trains usually operate inside a tunnel. Due to electrical interruption when a train gets halted train collision may occur Metro rail is operated both in tunnels as well as in overhead bridges. Hence after electrical interruption, automatic signal control is needed for avoiding huge accidents. By employing plc the automation can be achieved.

2. EXISTING SYSTEM

Metro network is having a single centralized operation control centre, ATP (Automatic Train Protection) and ATS (Automatic Train Supervision).Automatic Train Protection is helpful for the driver in preventing collision due to his mistake to observe a signal or speed restriction. The

telecommunication system acts as the backbone for signaling systems, and other systems such as SCADA and AFC are provided for operational and administrative requirements of metro network.

A. DEMERITS

Due to interruption of power supply caused because of external factors complete communication will be cut off and it is difficult to determine the exact location of the train. Due to interruption of power supply the doors cannot be opened under emergency conditions. Collision of trains may occur due to disconnected communication system.

3. PROPOSED SYSTEM

PLC is used as a main tool for controlling the signals of the train and taking appropriate actions. Programmable Logic Controller is used for controlling the train signals when the train gets stopped inside the tunnel due to interruption of power system. SCADA is used for monitoring the signals and collecting the data of PLC.

Even after the interruption of power system Programmable Logic Controller assists in opening the emergency exit. This system can be implemented in underground as well as in flyover systems. Automatic Train Signal Control Method is being employed. This enhances the safety of Metro Rail System. Automatic Tunnel Light Turning On and Automated Inter Passage Door Opening assist the passengers to come out of the tunnels easily.

IR Sensors are placed at regular intervals in the track which senses the train’s movement and gives an input signal to the PLC. According to the input Signal given by IR pairs the PLC works. If in case the train stops inside a tunnel then the place where it is being halted can be exactly located and it is given as an input to the PLC.

Now PLC automatically controls the nearby signals automatically due to the instruction given from the control room. Since it can be done no human intervention is needed for clearing the communication problem. Hence the system enhances the communication and ensures the safety of the passengers.

A.ADVANTAGES

Train’s location can be easily identified and the signals can be controlled even after interruption of power supply. On controlling the signals collision of trains can be avoided. Even after the interruption of power system PLC operates and helps in opening the emergency exit to get the people out of the tunnel.

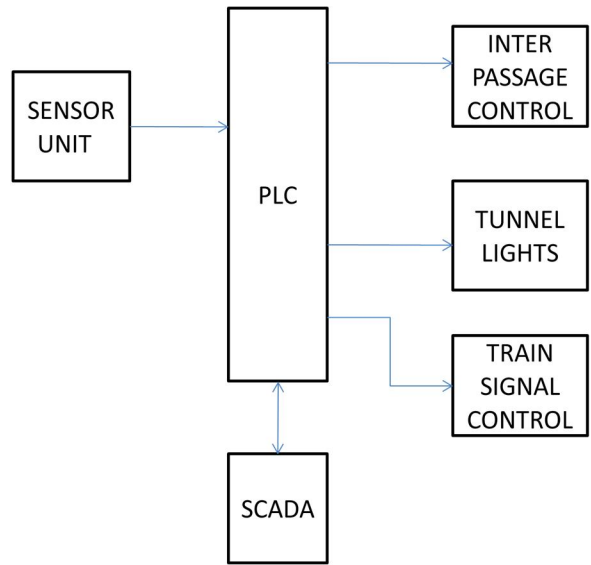

Figure1. Block Diagram for the proposed system

4. PROGRAMMABLE LOGIC CONTROLLER

A digitally operating electronic apparatus which uses a programmable memory for the internal storage of instructions for the implementing specific function such as logic, sequencing, timing, counting and arithmetic to control through digital or analog input/output modules various types of machines or processes.

The programmable controller offers solid-state reliability, lower power consumption and ease of expandability.

Overall a Programmable Logic Controller is a mini computer specifically designed for industrial and other applications. Examples are

- Hydraulic machines
- Robots
- Production processes
- Packaging Lines.
- Traffic Lights and signaling systems.

The bigger the process the more of a need we have for a PLC. We can simply program the PLC to count its inputs and turn the Outputs on for the specified time.

5. PLC – CX PROGRAMMER FOR CP1E

CX-Programmer, the programming software for all Omron's PLC series, is fully integrated into the CX-One software suite. CX-Programmer includes a wide variety of features to speed up the development of your PLC program New parameter-setting dialogues reduce

setup time, and with standard function blocks in IEC 61131-3 structured text or conventional ladder language, CX-Programmer makes development of PLC programs a simple drag & drop configuration.

Create advanced programs using data blocks of identical data types (Arrays), or different data types (Structures).. Symbol creation becomes quicker as memory allocation and management is automatic, and you can easily monitor all member symbols in the

Watch Window just by using their name. Using Structures and Arrays as In / Out variables for a Function Block, provides simple passing of many parameters in a uniform layout. This uniformity and clear data hierarchy can help program readability during development and maintenance. For the most complex program data, even nested structures, arrays of structures and structures with array elements are supported.

Special data types for TIMER (count-down) and COUNTER (count-up) symbols greatly simplify the use of timers/counters in ladder programs as rungs, to reset and check them you can simply access them by using their name. When used with the Auto Allocation feature, you can define a symbol of type TIMER or COUNTER and never have to worry about where it is stored. That means zero maintenance to resolve addresses when a program grows or rungs are copied to a new project. Arrays of timers and counters are also supported.

When typing instructions or symbol names a 'predictive-text' style browser shows you possible matches which can be easily clicked or selected. Symbol addresses for the next Input and Output are auto incremented to speed up new program creation, and a special Copy/Paste function allows quick duplication with sequential addresses. No need for any manual drawing of rung connections as this is filled in automatically – even for more complex operations like parallel contacts (OR) or Function Block invocations. This all makes programming smarter, quicker and more intuitive.

Early verification of Position Control function can display graphs of positions or speeds against time, verifying the action prior to transferring. Movements for up to 4 axis per task can be verified

1. One/two axis interpolation
2. Pulse output instruction

CX-Programmer now includes support for Sequential Function Charts (SFC):

- Enables the flow of the program to be understood at a glance

- Helps to achieve a structured program
- Easy monitoring and debugging

With ST numerical processing or complex logical comparisons become simple! A program to average hundreds of points requires only a few lines and therefore can be developed in minutes. CX-Programmer includes enhanced program comparison enabling detailed comparison of function blocks and structured text. Address Reference Tool can search with wildcards (* or ?) to find the symbol you want to check EM Area can be addressed as symbols including force set/reset functionality Automatic connection to serial, USB and Ethernet IP devices Easy to use ladder editor Supports whole Omron PLC product range for the last 20 years including CS1, CJ1/CJ2, C and CV families

6. SCADA - WONERWARE INTOUCH 9.5

A SCADA system consists of a number of components.

- The central SCADA master system.
- A communications network.
- The RTU's. Remote Telemetry (or Terminal) Units.
- Field instrumentation.

The SCADA RTU is a (hopefully) small rugged computer, which provides intelligence in the field, and allows the central SCADA master to communicate with the field instruments. It is a stand-alone data acquisition and control unit. Its function is to control process equipment at the remote site, acquire data from the equipment, and transfer the data back to the central SCADA system. There are two basic types of RTU - the "single board RTU" which is compact, and contains all I/O on a single board, and the "modular RTU" which has a separate CPU module, and can have other modules added, normally by plugging into a common "backplane" (a bit like a PC motherboard and plug in peripheral cards). The single board RTU normally has fixed I/O e.g. 16 digital inputs, 8 digital outputs, 8 analogue inputs, and say 4 analogue outputs. It is normally not possible to expand its capability. The modular RTU is designed to be expanded by adding additional modules. Typical modules may be a 8 analog in module, a 8 digital out module. Some specialized modules such as a GPS time stamp module may be available.

B.INTERNET & WEB-BASED SCADA

Traditionally SCADA communications has been Point-to-Multipoint serial communications over lease line or private radio systems (i.e. RS232, RS485). Internet SCADA or Web-based SCADA makes use of IP technology in SCADA and can range from IP

tunnels over satellite, frame relay, fiber, radio to link SCADA networks to central office to individually IP addressed instruments or devices.

7. IR SENSOR PAIR

An IR proximity sensor works by applying a voltage to a pair of IR light emitting diodes (LED's) which in turn, emit infrared light. This light propagates through the air and once it hits an object it is reflected back towards the sensor. If the object is close, the reflected light will be stronger than if the object is further away.

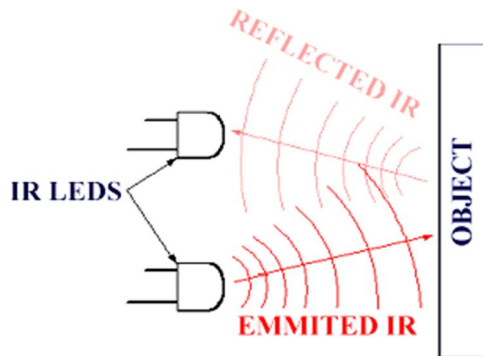

Figure 2. IR Pair Operation

The sensing unit (for this experiment a Sharp IS471FE will be used), in the form of an integrated circuit (IC), detects the reflected infrared light, and if its intensity is strong enough, the circuit becomes active. When the sensing unit becomes active, it sends a corresponding signal to the output terminal which can then be used to activate any number of devices. For the purpose of this exercise, a small green LED will turn on when the sensor becomes active.

8. OPERATION

The PLC activates its output terminals in order to switch things on or off. The decision to activate an output is based on the status of the system's feed-back sensors and these are connected to the input terminals of the PLC. The decisions are based on logic programs stored in the RAM and/or ROM memory. They have a central processing unit (CPU), data bus and address bus. A typical unitary PLC is shown below.

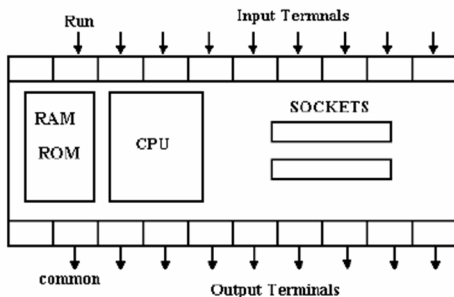

Figure 3. PLC architecture and terminology

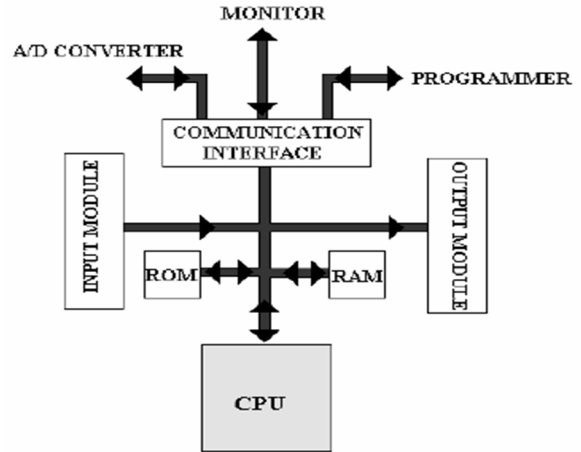

Figure 4. PLC Architecture

The Buffers act as switches that isolate the lines on either side if required. A, B and C are latches that passes the data from one side to the other when told to do so. Digital data is passed around through buses. The buses were originally 4 parallel lines but as technology progressed this become 8, then 16 and now 32. The buses are connected to memory chips. In a memory chip, digital numbers are stored in locations. The number is the data and the location is the address. Data can be sent to or brought from memory locations by either writing it or reading. The lines labeled R and W are signal lines that makes the CPU read or write. A REGISTER is a temporary memory location where data is put to be manipulated and then taken away. The CLOCK line is pulsed at a regular rate to synchronize the operations. Currently this has reached a rate measure in Giga Hertz (1000 million times a second).The Reset line when activated resets the program Counter to Zero. The operations are carried out to a set of instruction (the program) and these are decoded in the ID (Instruction Decoder).

A.MEMORY

The processor memory module is a major part of the CPU housing. Memory is where the control plan or program is held or stored in the computer. The information stored in the memory relates to the way the input and the output data should be processed. The complexity of the control plan determinates the amount of memory required. Most PLC memories are expandable in fixed increments. Memory elements store individual pieces of information called bits. These elements are mounted on printed circuit boards. PLC memory capacity may vary from less than 100bits to over 48K bits. The actual control program is held within electronic memory storage components such as RAM and E2PROM.The most popular ROM used in PLC's today is ultra violet programmable read only memory. The most common R/W memory used in

PLC's is magnetic core. The main advantages of the core memory is that it can be easily altered which is especially useful when program variables such as set points must be changed several times a work shift, day or week.

B. I/O MODULES (INTERFACES)

The input module performs four tasks electronically. First, it senses the presence or absence of an input signal at each of its input terminals. The input signal tells what switch, sensor or other signal is on or off in the process being controlled. Second, it converts the input signal for on a high to a DC level usable by the module's electronic circuit. For a low or off input signal, no signal is converted indicating off. Third, the input module carries out electronic isolation by electronically isolating the input module output from its input. Finally, its electronic circuit must produce an output to be sensed by the PLC CPU. A typical input module has 4, 6, 8,12,16,32 terminals, plus common and safely ground terminals. The figure shows the circuit for one terminal. The first block receives the input signal from the switch, Sensor, and so on .For AC voltage inputs, the DC converter consist of rectifiers and a means to step the voltage down to usable level, usually with a Zener diode.

C. HOW PLC CONTROLLER WORKS

Basis of a PLC function is continual scanning of a program. The Scanning process involves three basic steps

Step 1:

Testing input status. First the plc checks each of its input with intention to see which one has status on or off. In other words it checks whether a switch or a sensor etc., is activated or not. The information that the processor thus obtains through this step is stored in memory in order to be used in the following steps

Step 2:

Programming execution: Here a plc executes a program instruction by instruction based on the program and based on the status of the input has obtained in the preceding step, and appropriate action is taken. The action might be activation of certain outputs and the results can be put off and stored in memory to be retrieved later in the following step.

Step 3:

Check up and Correction of the output status: Finally, a plc checks up output signals and adjust it has needed. Change it's perform is based on the input status that had been read during the first step, and based on the result of the program execution in step two. Following execution of step three plc returns

a beginning of the cycle and continually repeats these steps.

D.BASIC INSTRUCTIONS

Load: The load (LD) instruction is a normally open contact. It is sometimes also called examine if on. (XIO) (as in examine the input to see if its physically on) The symbol for a load instruction is shown below.

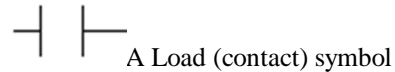

This is used when an input signal is needed to be present for the symbol to turn on. When the physical input is on we can say that the instruction is true. We examine the input for an on signal. If the input is physically on then the symbol is on. An on condition is also referred to as logic 1 state.

This symbol normally can be used for internal inputs, external inputs and external output contacts. Internal relays don't physically exist. They are simulated (software) relays.

Load Bar: The Load Bar instruction is a normally closed contact. It is sometimes also called Load Not or examine if closed. (As in examine the input to see if it is physically closed) The symbol for a Load bar instruction is shown below.

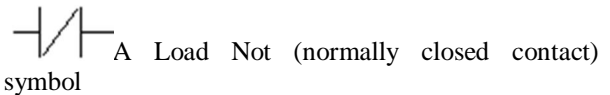

This is used when an input signal does not need to be present for the symbol to turn on. When the physical input is off we can say that the instruction is true. We examine the input for an off signal. If the input is physically off then the symbol is on. An off condition is also referred to as a logic 0 state.

This symbol normally can be used for internal inputs, external inputs and sometimes, external output contacts. Remember again that internal relays don't physically exist. They are simulated (software) relays. It is the exact opposite of the Load instruction.

Table I: Truth Table

Logic State	Load	Load Bar
0	False	True
1	True	False

Out: The Out instruction is sometimes also called an Output Energize instruction. The output instruction is

like a relay coil. Its symbol looks as shown below.



An OUT (coil) symbol

When there is a path of True instructions preceding this on the ladder rung, it will also be True. When the instruction is true it is physically On. We can think of this instruction as a normally open output. This instruction can be used for internal coils and external outputs.

Out bar

The Out bar instruction is sometimes also called an Out Not instruction. Some vendors don't have this instruction. The Out bar instruction is like a normally closed relay coil. Its symbol looks like that shown below.



An OUT Bar (normally closed coil) symbol

When there is a path of false instructions preceding this on the ladder rung, it will be true. When the instruction is true it is physically on. We can think of this instruction as a normally closed output. This instruction can be used for internal coils and external outputs. It is the exact opposite of the Out instruction.

Table II: Truth Table

Logic State	Out	Out Bar
0	False	True
1	True	False

9. RF TRANSMITTER AND RECEIVER

An RF transmitter generates radio frequency waves [3] in its circuits, and to this 'carrier signal', it adds the information part by modulating the carrier signal. This composite signal (carrier plus information) is then fed to an antenna (aerial). The aerial induces a corresponding signal into the atmosphere, by altering the Electric and Magnetic fields at (obviously) the same frequency. The impedance of 'free space' is few tens of Ohms to a few hundreds of Ohms. [Impedance may be considered analogous to resistance, but with reactive properties as well]. The power emitted by the transmitter can vary from a megawatt or so (for VLF signals) to a few watts for handheld devices. RF receiver receives the signal from the atmosphere, from its own aerial. The receiver aerial is often quite simple, and the signal level is typically of a few micro volts. This it tunes in (gets rid of unwanted signals and amplifies only the wanted ones). The receiver circuits then strip the information

part of the signal from the carrier part, and amplify this to a useful level for audio or video. The actual signal into the loudspeaker will be a few tens of volts. In spite of the inefficiency of loudspeakers, (often only a few %) the signal eventually appears at a level that may be heard. A background radio will be few mw of power. Even a very loud sound is only a few watts of radiated (sound) energy. 4.5.3 RF HT12E Transmitter HT12E converts the parallel inputs into serial output. It encodes the 12 bit parallel data into aerial for transmission through an RF transmitter. These 12 bits are divided into 8 address bits and 4 data bits. HT12E has a transmission enable pin which is active low. When a trigger signal is received on TE pin, the programmed addresses/data are transmitted together with the header bits via an RF or an infrared transmission medium. HT12E begins a 4-word transmission cycle upon receipt of a transmission enable. This cycle is repeated as long as TE is kept low. As soon as TE returns to high, the encoder output completes its final cycle and then stops.

10. WORKING

Power outage is a major problem today. When power outage occur the train stops immediately and entire communication system gets disrupted. Thus when a train is coming in the same track may lead to unavoidable accidents. In order to overcome this problem IR SENSORS are placed at regular intervals in the track which senses the movement of the train continuously and gives it as an input signal to PLC and it is continuously being monitored by SCADA. Even after power outage PLC automatically controls the nearby signals and it avoids any accidents. By using the backup from the train Inter Passage doors are automatically opened by PLC and tunnel lights are turned on automatically for guiding the passengers inside the tunnel which is generally dark. In order to avoid passengers to walk through a long distance a ladder arrangement is provided at the top of the tunnel. RFID is being used for wireless communication of the train in order to detect the nearby station and announcement to the passengers.

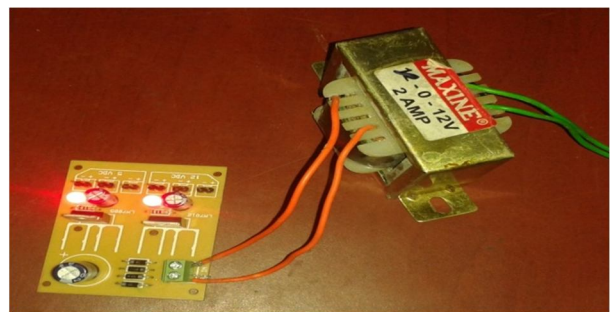

Figure5. Power Supply Unit



Figure 6. Hardware Implemented

11. CONCLUSION

Thus by determining the train's movement the signals can be controlled automatically which will avoid train accidents. This system also provide other safety measures such as tunnel light turning on, Inter Passage Door opening and Ladder arrangement for assuring the safety of Passengers. This arrangement increases the safety of passengers and it strengthens the communication of the train. This system can be implemented both in Underground as well as in Flyover system. Future work includes automatic changeover of supply lines when power outage occurs inside the tunnel.

REFERENCES

- [1]. IEEE Standard for CBTC Performance and Functional Requirements (1474.1-1999).IEEE Rail Transit Vehicle Interface Standards Committee of the IEEE Vehicular Technology Society, 1999. Accessed January 2011.
- [2]. CBTC Projects. www.tsd.org/cbtc/projects, 2005. Accessed June 2011.
- [3]. CBTC radios: What to do? Which way to go? Tom Sullivan, 2005. www.tsd.org. Accessed May 2011.
- [4]. Semi-automatic, driverless, and unattended operation of trains . IRSE-ITC, 2010. Accessed through www.irse-itc.net in June 2011
- [5]. IEEE RTVISC meetings are open. For committee and working group meeting dates, minutes and related information see: <http://www.tsd.org/rsc>.
- [6]. <http://www.echelon.com/Products/Core/protocol/Default.htm>
- [7]. I.Yoda, K.Sakaue. "Ubiquitous Stereo Vision for Controlling Safety on Platforms in Railroad Station," IEEJ Tr. on Electronics, Information and Systems, Vol. 124, No. 3, Mar., pp.805-811, 2004.
- [8]. Kruse, S.Milch, H.Rohling. "Multi Sensor System for ObstacleDetection in Train Applications," Proc. of *IEEE Tr.*, June, pp.42-46, 2003.
- [9]. Y.Sasaki, N.Hiura. "Development of Image Processing Type Fallen Passenger Detecting System," JR-EAST Technical Review Special Edition Paper, No. 2, pp.66-72, 2003.